

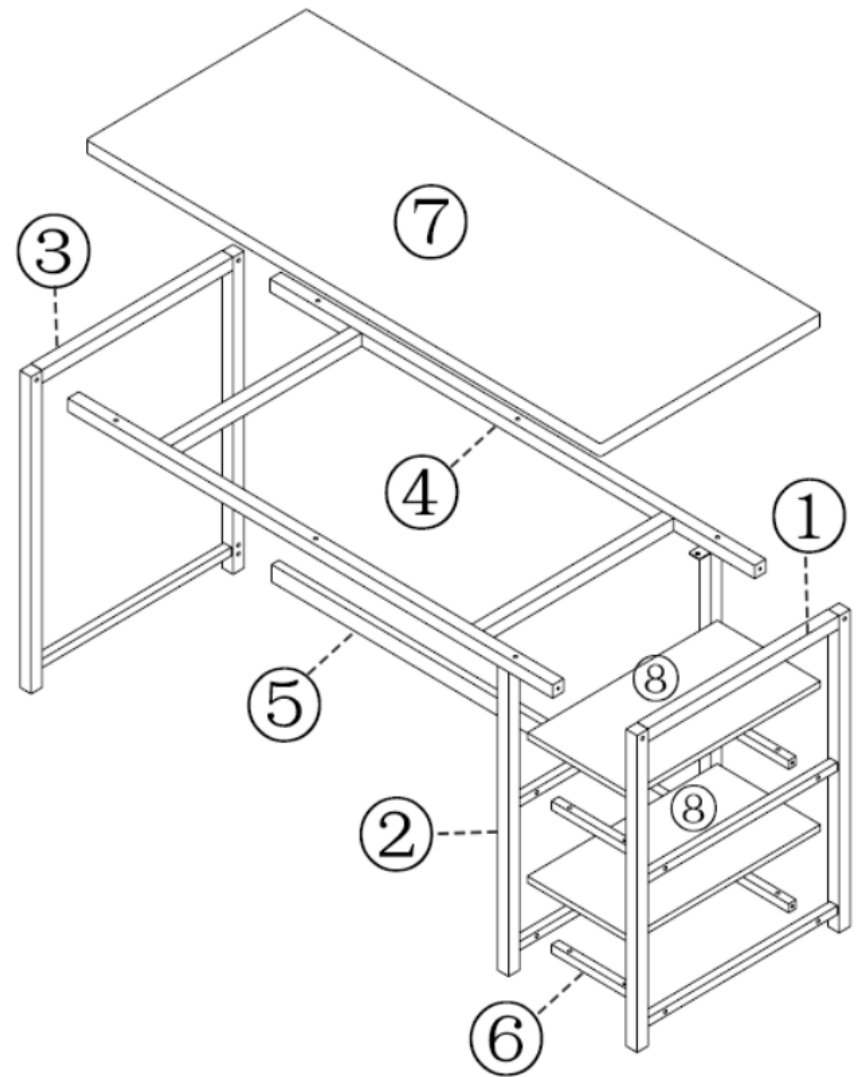

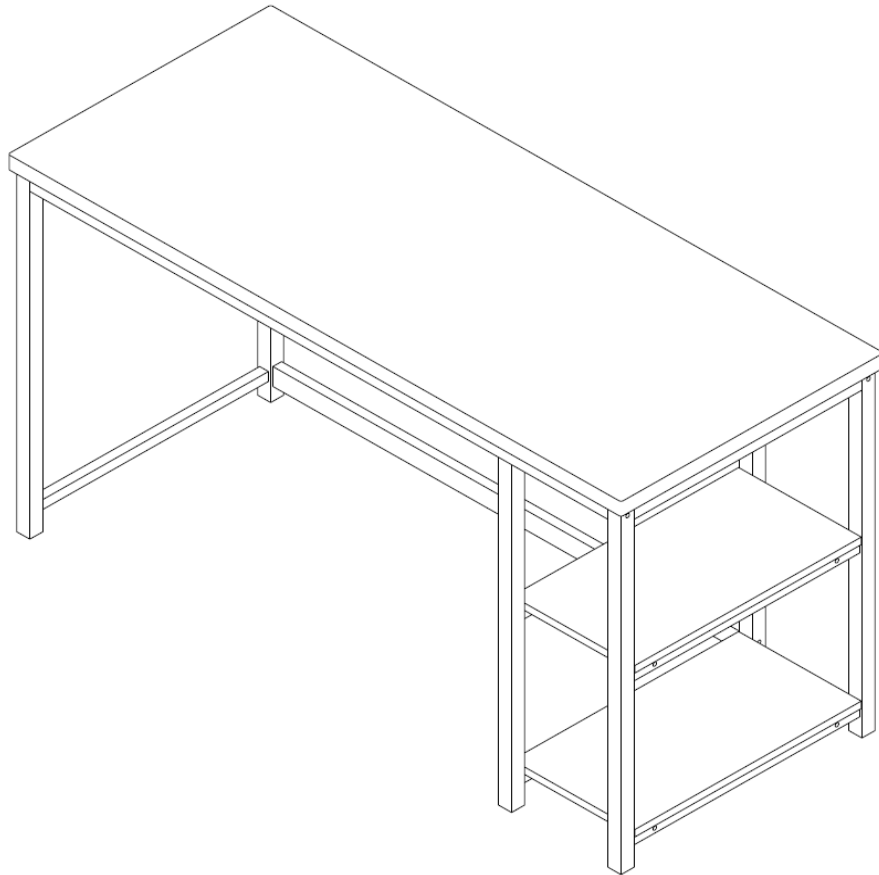

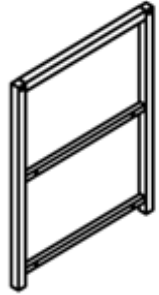

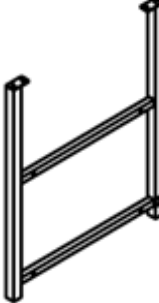
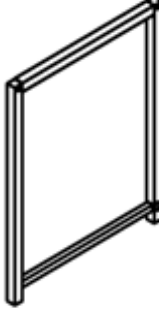
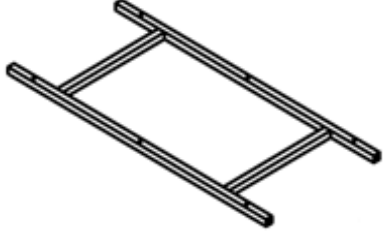

# COMPUTER DESK ASSEMBLY INSTRUCTION

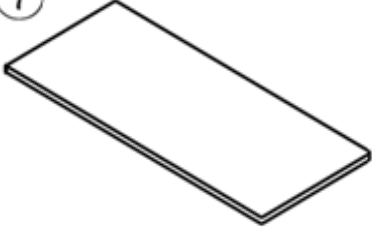
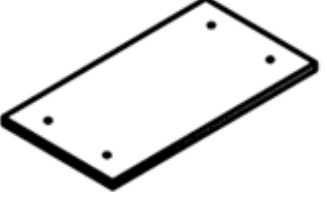
## COMPUTER DESK



# Parts & Hardware

<p>①</p>  <p>Right Shelf Leg 1pc</p>	<p>②</p>  <p>Left Shelf Leg 1pc</p>	<p>③</p>  <p>Side Leg 1pc</p>	<p>④</p>  <p>Top Frame 1 pc</p>	
<p>⑤</p>  <p>Long Crossbar 1 pc</p>	<p>⑥</p>  <p>Short Bar 4 pcs</p>	<p>⑦</p>  <p>Desk Top 1 pc</p>	<p>⑧</p>  <p>Shelf 2 pcs</p>	
<p>A</p>  <p>Extra Long Bolt M6*50mm 8 pcs</p>	<p>B</p>  <p>Long Bolt M6*40mm 14 pcs</p>	<p>C</p>  <p>Medium Bolt M6*30mm 8 pcs</p>	<p>D</p>  <p>Short Bolt M6*12mm 2 pcs</p>	<p>E</p>  <p>Allen Key 1 pc</p>

# COMPUTER DESK ASSEMBLY INSTRUCTION

Step 1: Align two Short Bars (⑥) to the first Shelf (③). Insert 4 Medium Screws (C) and tighten with supplied Allen Key (E). Repeat it for the second Shelf.

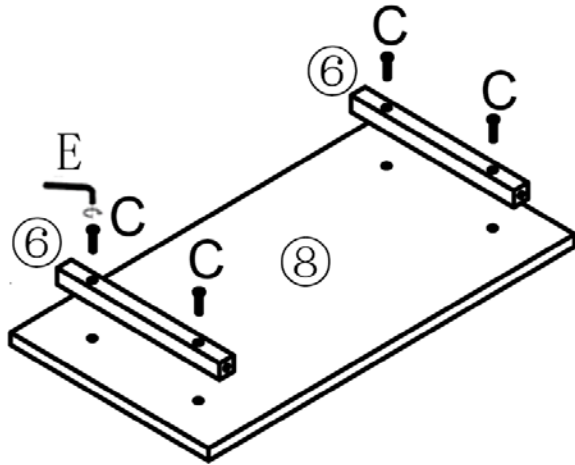

Step 2: Connect Left Shelf Leg (②) and Right Shelf Leg (①) to two assembled shelves (⑧) by inserting 8 Long Screw (B). Make sure Left Shelf Leg is on the left and Right Shelf Leg is on the right as shown. Do not fully tighten all bolts until all parts are in place.

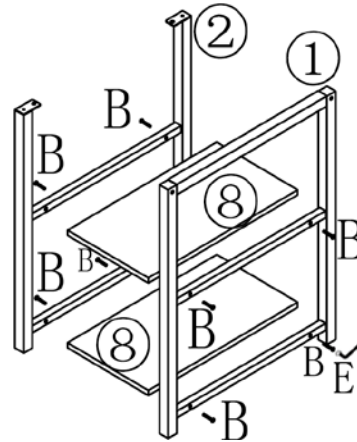

Step 3: Attach Long Crossbar (⑤) to Left Shelf Leg (②) by using 2 Extra Long Screw (A) with supplied Allen Key (E). Do not fully tighten all bolts until all parts are in place.

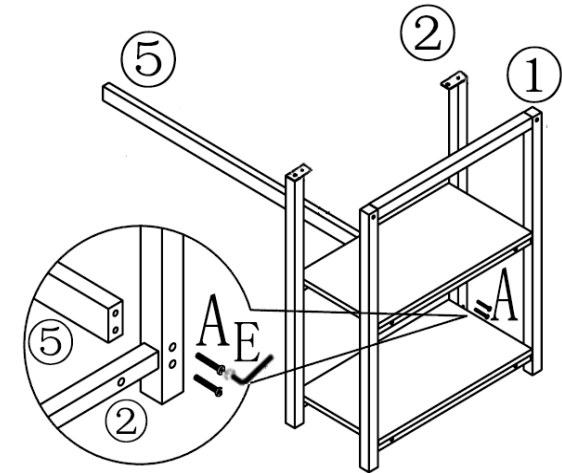

Step 5: Attach Top Frame (④) to the assembled shelf leg by using 2 Extra Long Screw (A) to connect Right Shelf Leg (①) and using 2 Short Screw (D) to connect Left Shelf Leg (②) with supplied Allen Key (E) as shown.

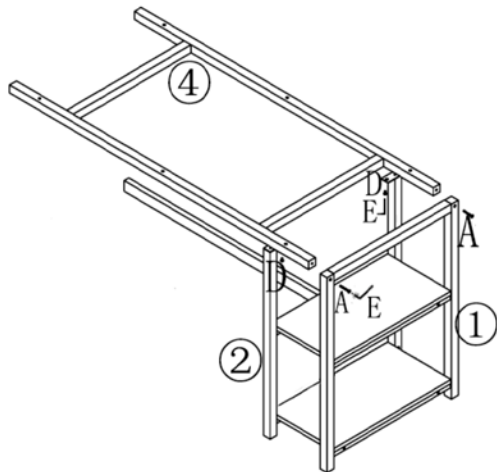

Step 6: Attach Side Leg (③) to the assembled frame (④⑤) by using 4 Extra Long Screw (A) with supplied Allen Key (E).

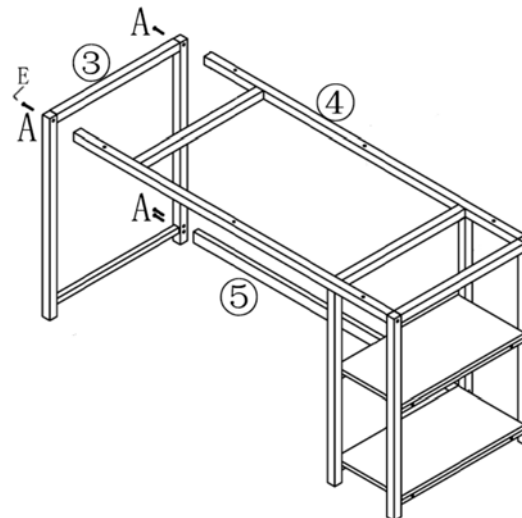

Step 7: Align Desk Top (⑦) to the assembled Top Frame (④). Insert 6 Long Screws (B) and tighten with supplied Allen Key (E).

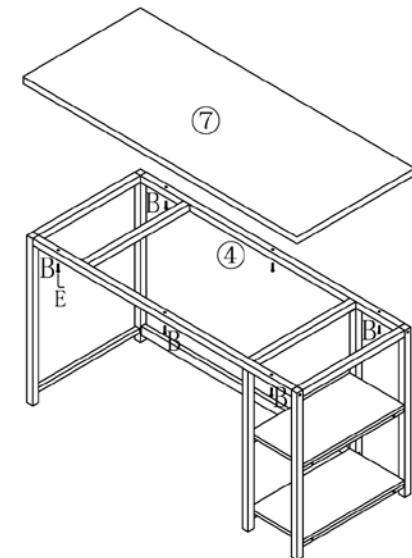

# COMPUTER DESK ASSEMBLY INSTRUCTION

Thank you for purchasing our computer desk. Be sure to check all packing material carefully for small parts that may have come loose inside the carton during shipment.

## PRE-ASSEMBLY

- (1) Proper assembly of this item requires 2 people.
- (2) Do not dispose of any contents until assembly is completed to avoid accidentally discarding small parts or hardware.
- (3) Remove all parts and hardware from box and lay out on a carpeted or scratch-free work surface, such as the cardboard, as this will avoid damaging any parts during assembly.
- (4) Do not fully tighten all bolts until all parts are in place. Failure to follow these instructions may cause the bolts to misalign during assembly.

## CARE INSTRUCTIONS

- (1) Hardware may loosen overtime. Periodically check that all connections are tight.
- (2) Wipe with a soft, dry cloth. To protect finish, avoid the use of chemicals and household cleaners.
- (3) All hot serving dishes should be placed on a pad.
- (4) Any liquid spilled onto the furniture should be cleaned up immediately with a damp cloth.